



BW-1200 Bore Welder



• Applications

- Logging
- Mining
- Construction
- Marine
- Pulp and Paper
- Manufacturing Industries
- Custom Designed Applications

• Product Description

This 500 amp machine is York's largest and most powerful welder, with a range of 12 to 120 inches (304.8 – 3048 mm) and optional weld strokes of 24, 36 and 48 inches (609, 914, and 1219 mm). Torch lengths are available from 12 inches to 10 or more feet (304.8 – 3048 mm). The welder has many programmable operation modes, a maximum current of 500 amps and uses wire sizes .045 to .062 inches (1.14 – 1.57 mm). The water cooled torch length will be configured to meet specific applications.

• Advantages

- Automated
- Programmable
- Water cooled
- Works with most wire feeders
- Customizable – Can be configured to any application from 1 to 10 plus feet
- Can be mounted on optional stand or fastened to job

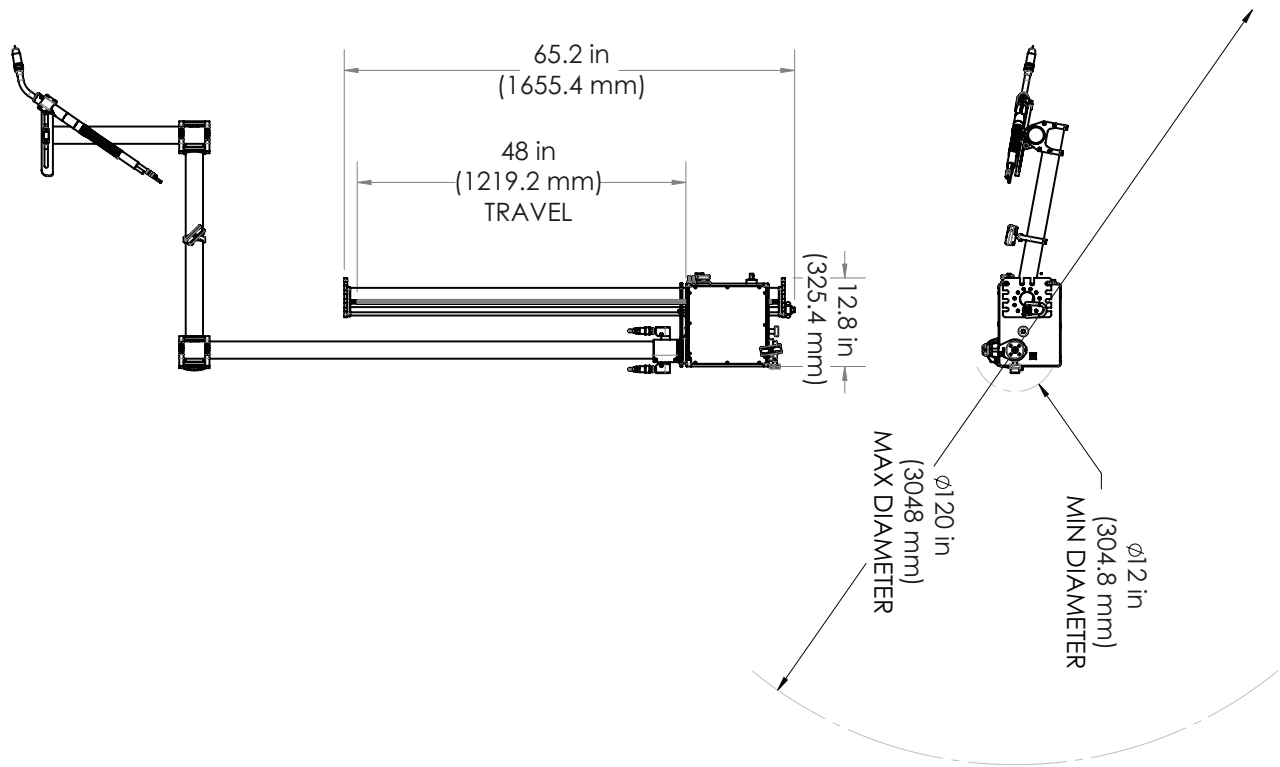

Welding Process	MIG
Bore Range	12 - 120 in (304.8 – 3048 mm)
Optional Weld Stroke	24, 36, and 48 in (609, 914, and 1219 mm)
Max. Weld Current	500 amps
Step Size	0 - .4 in (0 - 10.16 mm)
Welding Wire Size	.045 - .062 in (1.14 – 1.57 mm)
Optional Torch Lengths	Adjustable from 12 in - 10 + ft (304.8 – 3048 mm) <i>Torch lengths need to be selected based on application</i>
Operation Modes	Precision Step Process - circular OD/ID, segment, skip, unidirectional / bidirectional, depth of hole, pause and resume.
Liquid Cooled Housing & Torch	
Modular	
Multi Skip Welding	1 - 99
Programmable Torch Positioning	Standard
Control Box	Hand Held
Welding Power Recommended	CV type
Wire Feeder Required	Burn back control
Recommended	4 Drive Rolls
Power Supply Requirements	120 V, 50/60 Hz 230 V, 50/60 Hz
Dimensions	65.5 X 10.5 X 15 in (1663.7 X 266.7 X 381 mm)
Welder Weight	Approx. 140 lbs (63.5 kg) <i>(weight does not include torch)</i>

